

Código	Curso Cilindro (mm)	Força daN		L K=50 (mm)	L min. (mm)	Vol. inicial (cm³)	Kg
		Pressão à 150bar Inicial	Final*				
PNRB-0,5-010	10	471,2	593,4	70	60	15,2	0,557
PNRB-0,5-015	15	471,2	607,9	80	65	20,9	0,590
PNRB-0,5-020	20	471,2	616,6	90	70	26,6	0,628
PNRB-0,5-025	25	471,2	622,3	100	75	32,3	0,653
PNRB-0,5-032	32	471,2	627,7	114	82	40,3	0,698
PNRB-0,5-038	38	471,2	631,0	126	88	47,1	0,733
PNRB-0,5-050	50	471,2	635,3	150	100	60,8	0,805
PNRB-0,5-063	63	471,2	638,3	176	113	75,6	0,875
PNRB-0,5-075	75	471,2	640,1	200	125	89,2	0,950
PNRB-0,5-080	80	471,2	640,8	210	130	94,9	0,983
PNRB-0,5-100	100	471,2	642,7	250	150	117,7	1,096
PNRB-0,5-125	125	471,2	644,2	300	175	146,2	1,248

\* Força Final Isotérmica a 20°C, curso totalmente atuado.

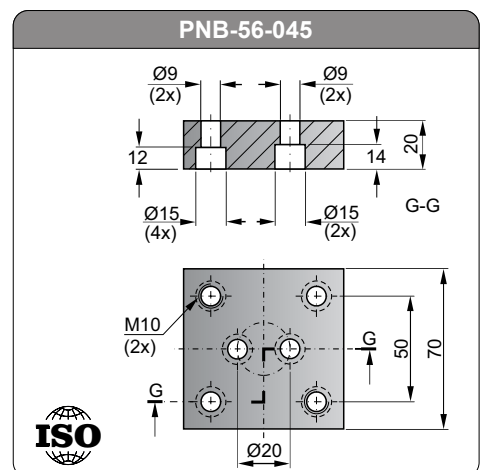
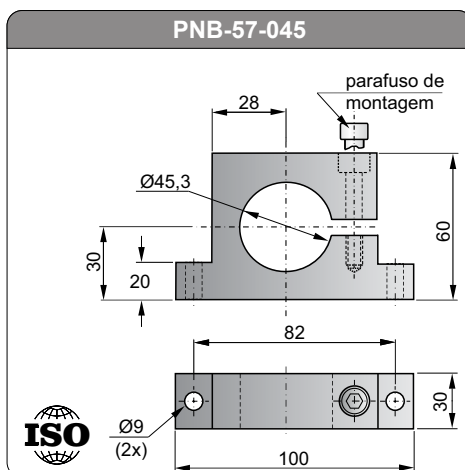
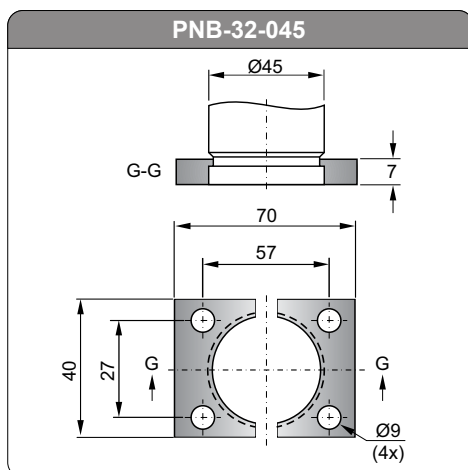
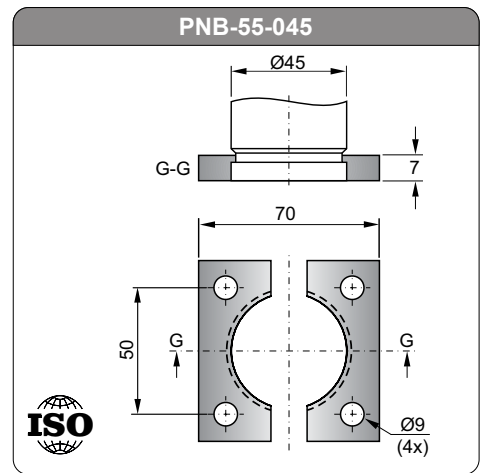
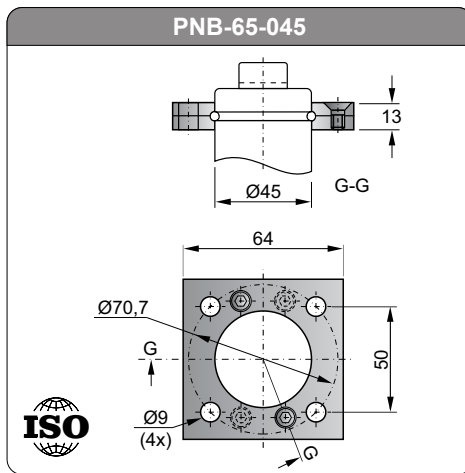
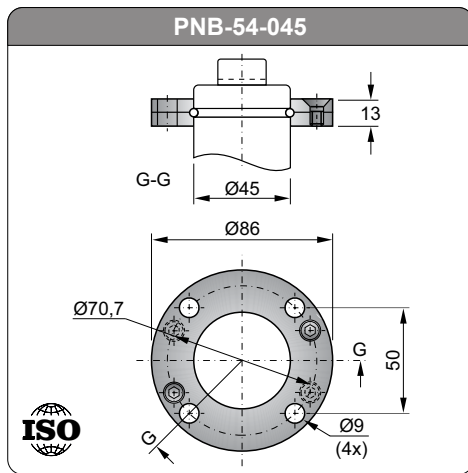
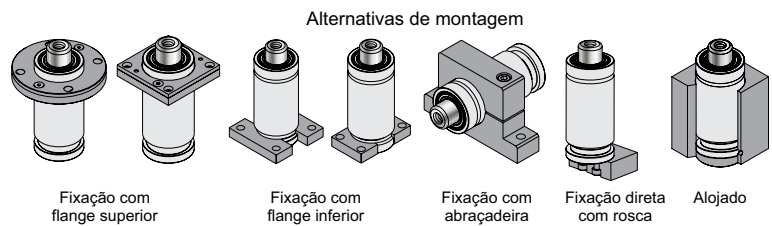

A PRODTY é detentora de patentes nacionais e internacionais, que cobrem características de seus produtos.