

Código	Curso Cilindro (mm)	Força daN		L K=70 (mm)	L min. (mm)	Vol. inicial (cm³)	Kg
		Pressão à 150bar Inicial	Final*				
PNRB-3,0-015	15	2.945	3.913	100	85	119,0	3.519
PNRB-3,0-020	20	2.945	4.006	110	90	148,2	3.654
PNRB-3,0-025	25	2.945	4.072	120	95	177,3	3.799
PNRB-3,0-032	32	2.945	4.136	134	102	218,1	3.975
PNRB-3,0-038	38	2.945	4.176	146	108	253,1	4.103
PNRB-3,0-050	50	2.945	4.230	170	120	323,1	4.408
PNRB-3,0-063	63	2.945	4.268	196	133	398,9	4.759
PNRB-3,0-075	75	2.945	4.293	220	145	468,8	5.047
PNRB-3,0-080	80	2.945	4.302	230	150	498,0	5.182
PNRB-3,0-100	100	2.945	4.327	270	170	614,6	5.655
PNRB-3,0-125	125	2.945	4.348	320	195	760,4	6.309

\* Força Final Isotérmica a 20°C, curso totalmente atuado.

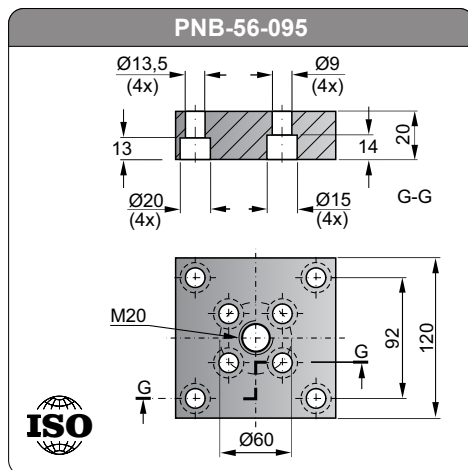
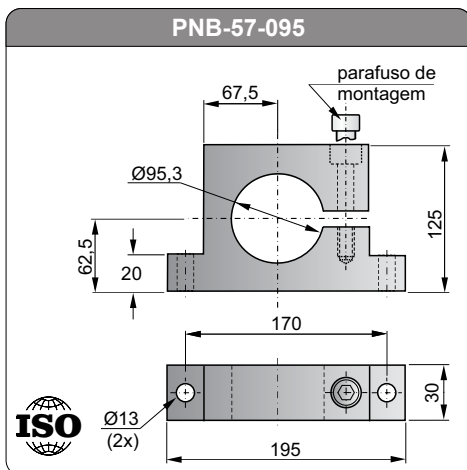
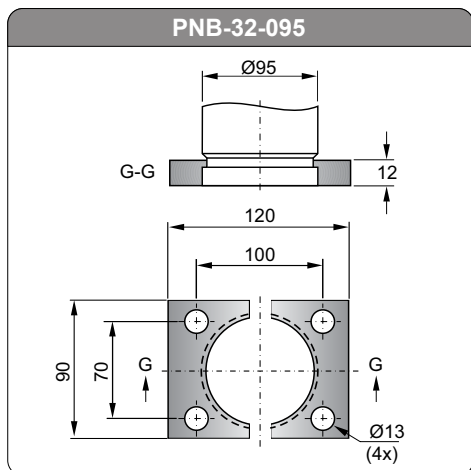
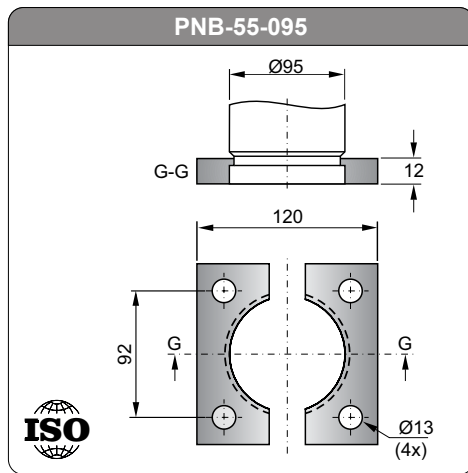
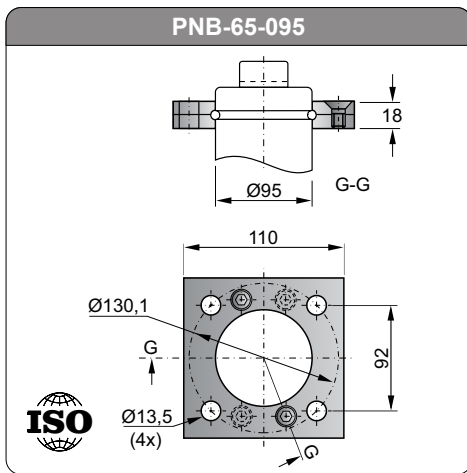
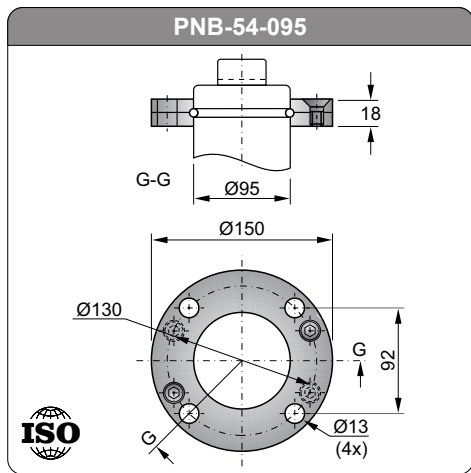
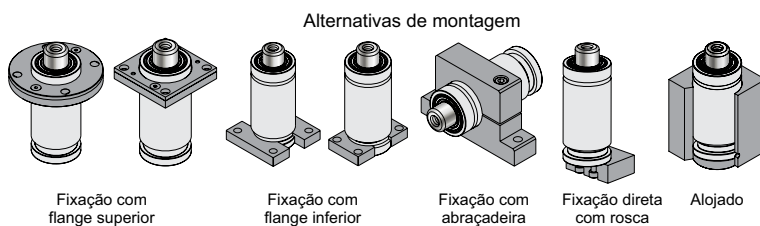

A PRODTY é detentora de patentes nacionais e internacionais, que cobrem características de seus produtos.