

Código	Curso Cilindro (mm)	Força daN Pressão à 150bar		L K=50 (mm)	L min. (mm)	Vol. inicial (cm <sup>3</sup> )	Kg	ISO
		Inicial	Final*					
PNFH-0,3-010	10	265,0	318,6	70	60	10,5	0,394	✓
PNFH-0,3-015	15	265,0	326,7	80	65	14,0	0,428	
PNFH-0,3-020	20	265,0	331,7	90	70	17,5	0,445	
PNFH-0,3-025	25	265,0	335,1	100	75	21,1	0,479	✓
PNFH-0,3-032	32	265,0	338,5	114	82	26,0	0,508	
PNFH-0,3-038	38	265,0	340,5	126	88	30,3	0,541	
PNFH-0,3-050	50	265,0	343,2	150	100	38,7	0,596	✓
PNFH-0,3-063	63	265,0	345,1	176	113	47,9	0,651	
PNFH-0,3-075	75	265,0	346,3	200	125	56,4	0,703	
PNFH-0,3-080	80	265,0	346,7	210	130	59,9	0,737	✓
PNFH-0,3-100	100	265,0	348,0	250	150	74,1	0,873	✓
PNFH-0,3-125	125	265,0	349,0	300	175	91,8	0,900	✓

\* Força Final Isotérmica a 20°C, curso totalmente atuado.

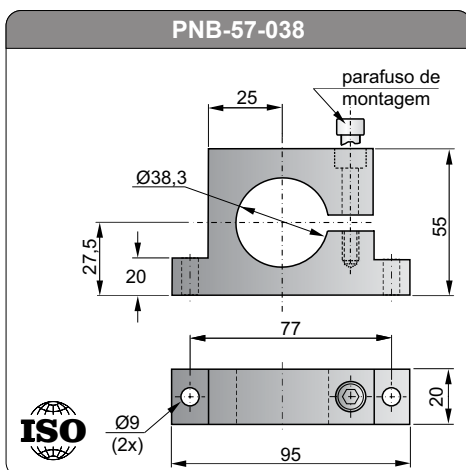
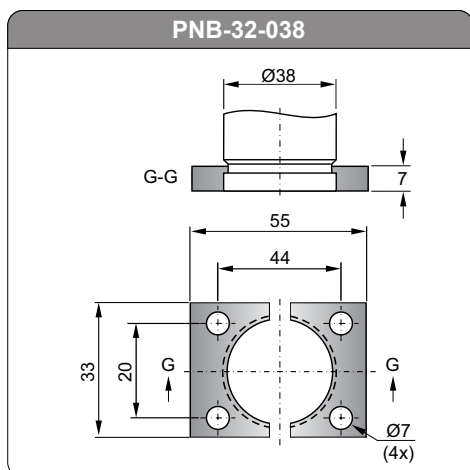
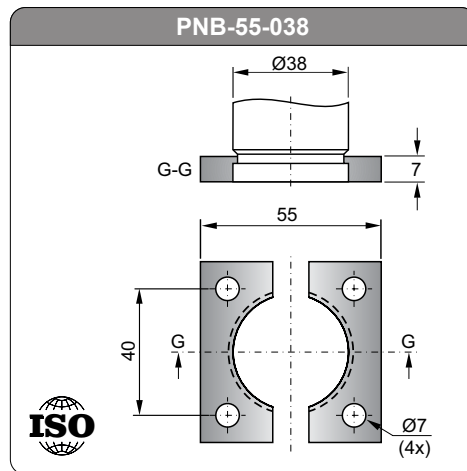
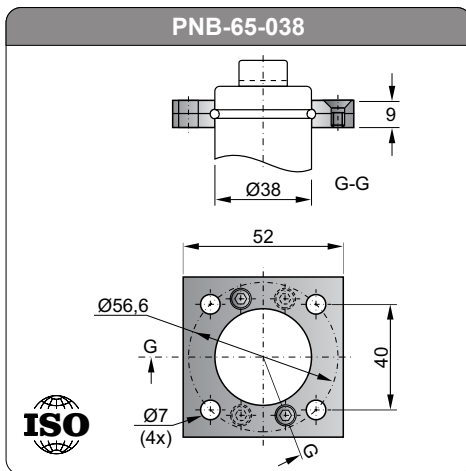
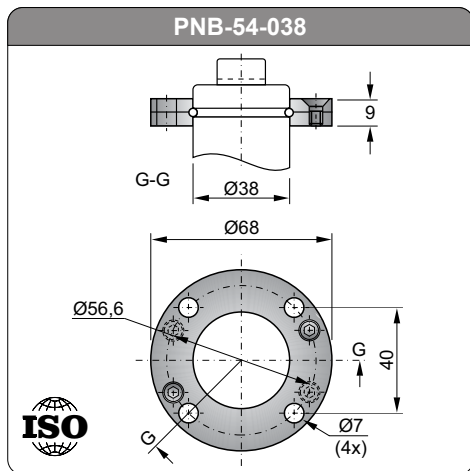
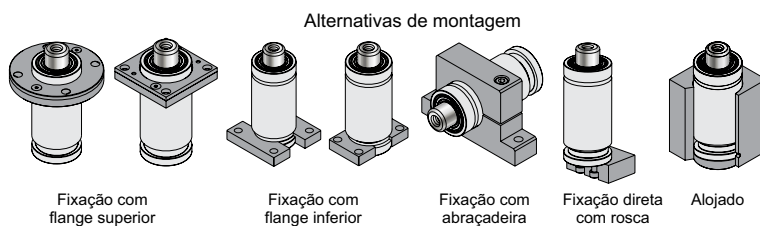

A PRODTY é detentora de patentes nacionais e internacionais, que cobrem características de seus produtos.